

PLAN VIEW

DIMENSIONS					
PIPE DIAM.	A (±1")	B MAX.	H (±1")	L (±1½")	W (±2")
6"	4½"	1"	3"	8¾"	12"
8"	5⅞"	3"	4"	14¼"	16"
10"	7½"	6"	6"	21"	24"
12"	4¾"	6"	6"	21"	24"
15"	6"	8"	6"	26"	30"
18"	7"	9"	6"	31"	36"
21"	8¼"	11"	6"	36"	42"
24"	9½"	12"	6"	42"	48"
30"	12"	15"	7½"	52½"	60"
36"	14"	18"	9"	63"	72"
42"	16"	21"	10½"	73½"	84"
48"	18"	27"	12"	84"	90"
54"	18"	30"	12"	84"	102"
60"	18"	33"	12"	87"	114"
66"	18"	36"	12"	87"	120"
72"	18"	39"	12"	87"	126"
78"	18"	42"	12"	87"	132"
84"	18"	45"	12"	87"	138"
90"	24"	37"	11"	87"	144"
96"	25"	35"	12"	87"	150"

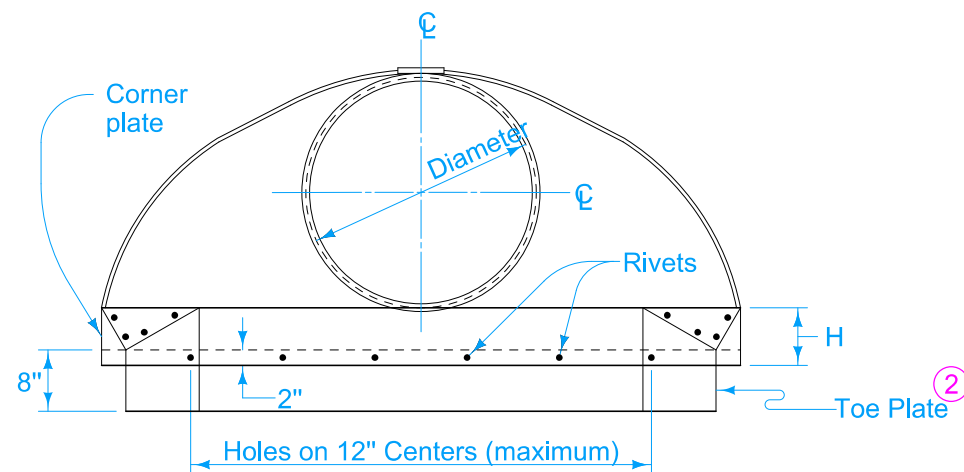

END VIEW

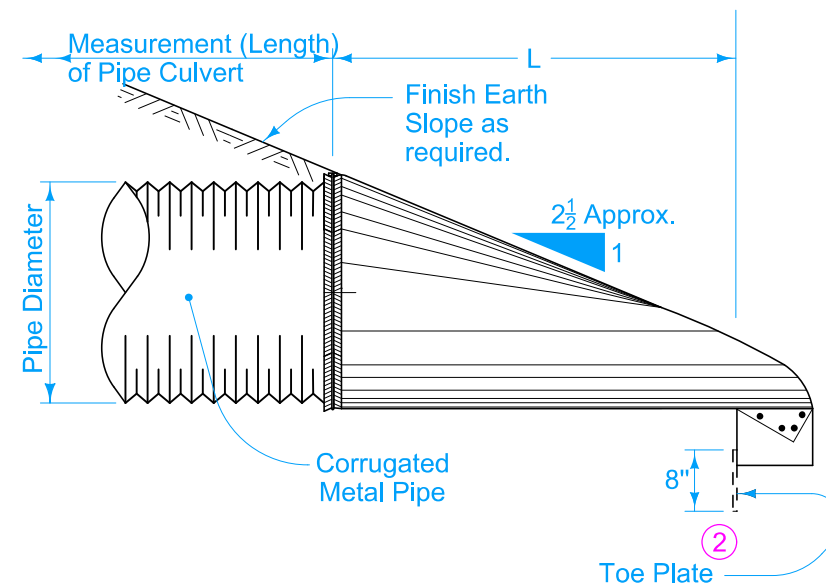

SIDE VIEW

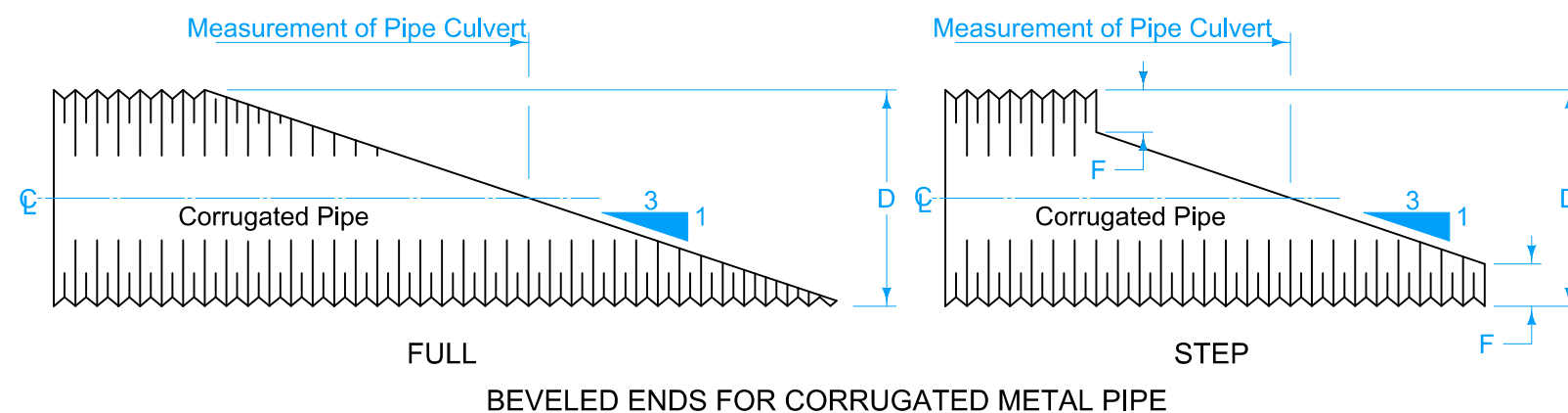

BEVELED ENDS FOR CORRUGATED METAL PIPE

BEVEL 3:1	
D	F
54"	3"
60"	6"
66"	9"
72"	12"
78"	15"
84"	18"
90"	21"
96"	24"

When specifically required as part of detail project plans, ends of pipe culvert may be provided with beveled ends as shown. Either Full Bevel or Step Bevel may be used unless one type is specified. The slope of the bevel is 3:1 unless specified otherwise. Beveled ends, when required, are incidental to the price bid for the culvert.

Install aprons and hardware fabricated from galvanized steel complying with Section 4141 of the Standard Specifications. Alternate design details may be submitted to the Engineer for approval.

Aprons may be attached to culvert pipe as follows:

- A. If normal culvert is of circumferential type, use an approved bolt or clamp to fasten directly to culvert.
- B. If normal culvert is of helical corrugation type:
 - 1. Use an approved sizing ring securely fastened to inside diameter of apron to connect the culvert pipe using special dimple band connector.
 - 2. "Dimple" bands are not allowed when a positive joint is specified.

Refer to Materials I.M. 441 for approved coupling devices.

Repair, to the Engineer's satisfaction, breaks or damage to the coating that occur during handling or installation.

Price bid for "Aprons, Metal" is full compensation for fabrication and installation of the metal apron.

- (1) On sizes 60 inches and larger, the reinforced edge should be supplemental with a galvanized stiffener angle attached with bolts.
- (2) Install Galvanized Toe Plate (same gage metal as apron) on all aprons 24 inch diameter and larger

Possible Contract Item:
Apron, Metal

Possible Tabulations:
104-3
104-5C

	REVISION	
	1	04-21-20
STANDARD ROAD PLAN		DR-203
REVISIONS: Added Designer Info button.		SHEET 1 of 1
 APPROVED BY DESIGN METHODS ENGINEER		
METAL PIPE APRONS AND BEVELED ENDS		