

PLAN FOR SW-508

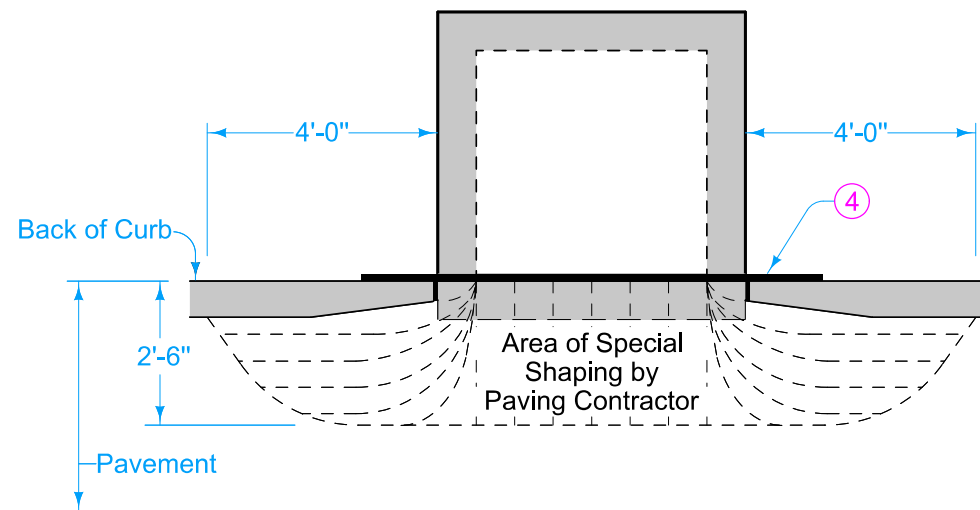

PLAN FOR SPECIAL SHAPING of INTAKE THROAT

This alternate method eliminates the need for boxouts at intakes. It requires the Contractor to pave through the insert area and special shape the pavement to drain into the intake. Include special shaping and reinforcement of insert area with price bid for P.C. Concrete Pavement. The intake well must be in place and the paver supported as it crosses over the intake well.

- ① Use a 2 inch thick resilient joint filler between the curb and intake top.
- ② 4" for 6 inch standard curb, 8" for 4 inch sloped curb.
- ③ 4'-0" for 6 inch standard curb, 3'-8" for 4 inch sloped curb.
- ④ Form used as a guide for shaping.

REINFORCING BAR LIST						
Type	Size	No. of Bars	6" Standard Curb		4" Sloped Curb	
			Length	WT. (lbs.)	Length	WT. (lbs.)
SW-508	4	14	76'-0"	51	73'-0"	49
SW-510	4	18	112'-0"	75	107'-8"	72

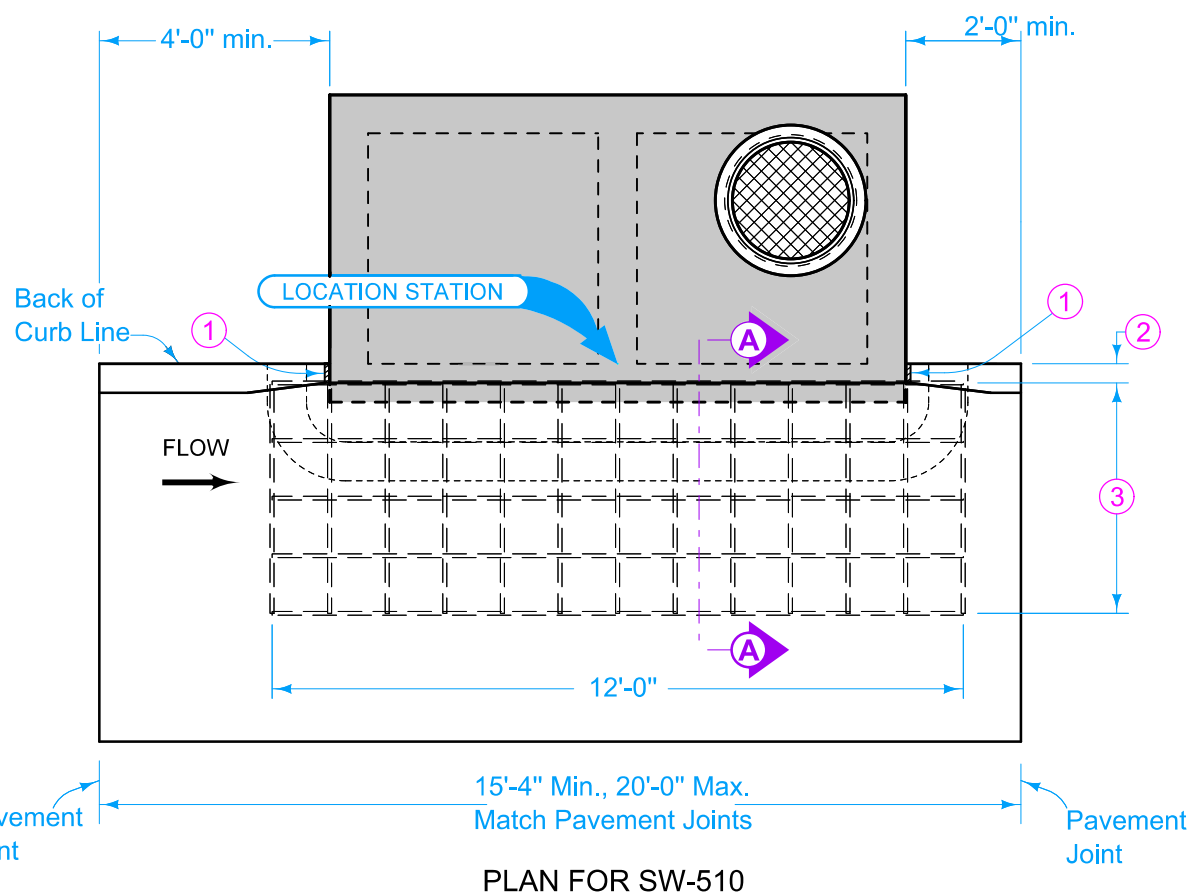

PLAN FOR SW-510

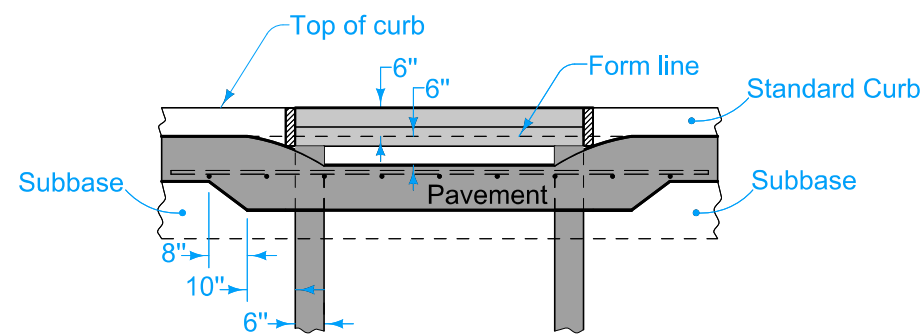

ELEVATION FOR SPECIAL SHAPING of INTAKE THROAT

	REVISION
	2 04-17-18
STANDARD ROAD PLAN	
SW-550	
SHEET 1 of 2	
REVISIONS: Added details for 4 inch sloped curb. Modified circle notes.	
 APPROVED BY DESIGN METHODS ENGINEER	
ALTERNATE CONSTRUCTION METHOD (SW-508 AND SW-510 INTAKE)	

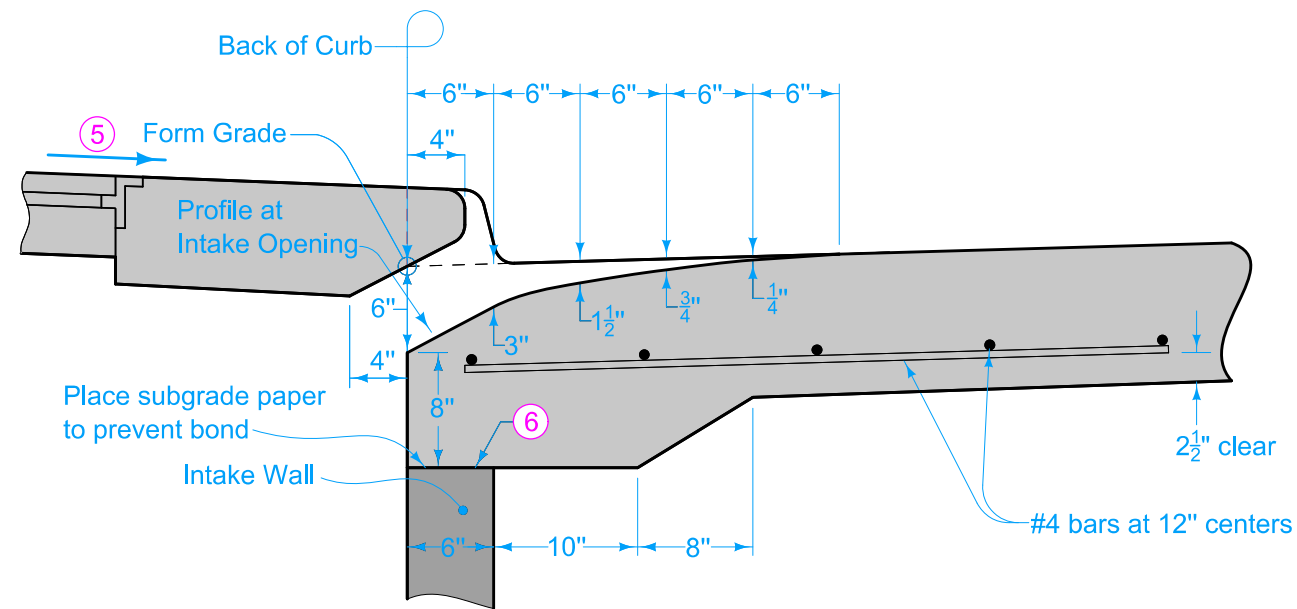

SECTION A-A
(Insert Area for 6 Inch Standard Curb)

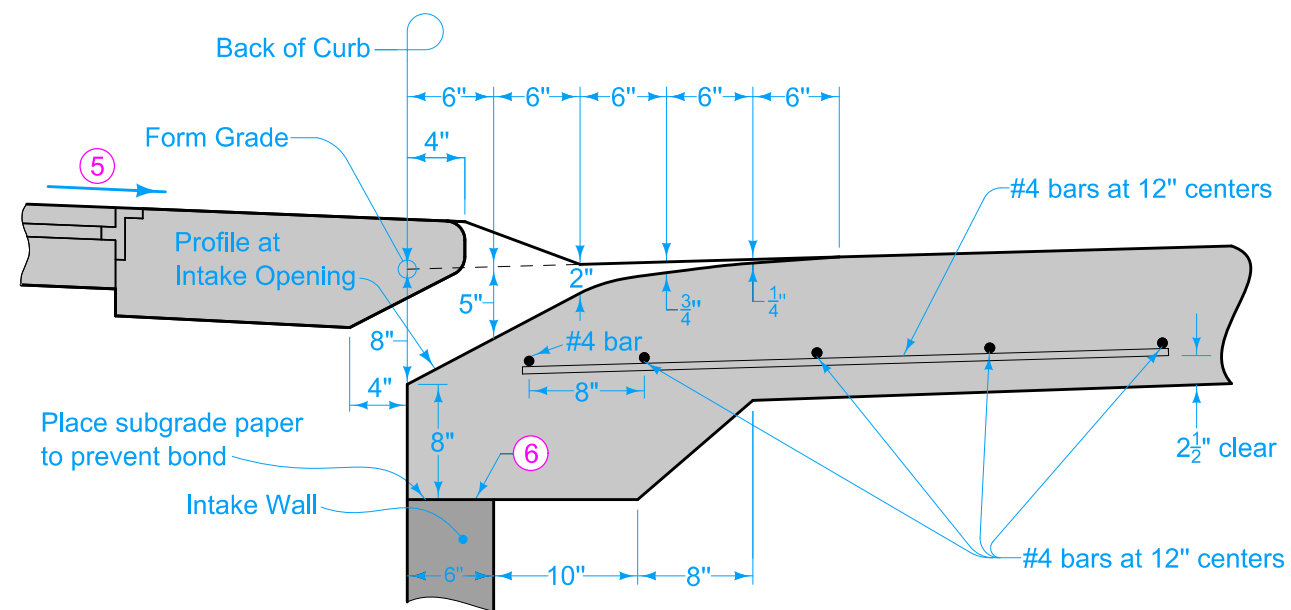

SECTION A-A
(Insert Area for 4 Inch Sloped Curb)

- ⑤ Slope of 1.5% or as specified in the contract documents.
- ⑥ Pavement shall rest on front wall of intake a minimum of 4 inches.

	REVISION	
	2	04-17-18
STANDARD ROAD PLAN		SW-550
		SHEET 2 of 2
REVISIONS: Added details for 4 inch sloped curb. Modified circle notes.		
APPROVED BY DESIGN METHODS ENGINEER		
ALTERNATE CONSTRUCTION METHOD (SW-508 AND SW-510 INTAKE)		