



Steel Cantilever Sign Truss Standards

Revised 03-2019: Modified Galvanized Steel Fastener Notes to address material availability issues. Modified Galvanized Steel Fastener Notes to address changes in ASTM Specifications.
 Revised 04-2020: Changed "Office of Bridges and Structures" to "Bridges and Structures" in Charpy V-notch toughness note for text uniformity. Changed "full-penetration groove weld" to "complete-joint-penetration groove weld" to conform to AWS nomenclature.
 Revised 12-2021: Clarified that a wrench with a 42-inch handle length is required to tighten anchor-bolt nuts to snug-tight condition.
 Revised 11-2025: This sheet reissued, sheet format update. Changed Iowa Department of Transportation Standard Specifications for Highway and Bridge Construction, "Series 2015" to "Series 2023".
 Steelcantilevertruss.dgn - SCST-01-17 - This sheet issued 07-2017.

Index for Steel Cantilever Sign Truss Standards

SCST-01-17	Index and Notes
SCST-02-17	Sign Support Views
SCST-03-17	Isometric View Typical Truss
SCST-04-17	Truss-to-Post Connection Details
SCST-05-17	Gusset Plate Connection Details
SCST-06-17	Post Base Support Details
SCST-07-17	Sign Attachment Details
SCST-08-17	Foundation Details - Spread Footing
SCST-09-17	Foundation Details - Drilled Shaft

Anchor-Bolt Nut Tightening Procedure:

- This work shall be performed only on days with winds less than 15 mph. All tightening of the nuts is to be done in the presence of the Inspector. Once the tightening procedure is started it must be completed on all of the base plate nuts without pause or delay.
- Properly sized wrenches designed for tightening nuts and/or bolts shall be used to avoid rounding or other damage to the nuts. Adjustable end wrenches or pipe wrenches shall not be used.
- Base plate, anchor bolts and nuts are to be free of any dirt or debris.
- Apply stick wax or beeswax to the threads and bearing surfaces of the anchor bolts, nuts and washers.
- Tighten top nuts so they fully contact the base plate. Tighten leveling nuts to snug-tight condition. Snug tight is defined as the full effort of one person on a wrench with a length equal to 42 inches. Apply force as close to the end of the wrench as possible. Pull firmly by leaning back and using entire body weight on the end of the wrench until the nut stops rotating. Use a minimum of two separate passes of tightening. Sequence the tightening in each pass so that the nut on the opposite side, to the extent possible, will be subsequently tightened until all nuts in that pass have been tightened.
- Tighten top nuts to snug tight as described for the leveling nuts.
- Match-mark the top nuts and base plate using paint, crayon or other approved means to provide a reference for determining the relative rotation of the nut and base plate during tightening. Using a striking or hydraulic wrench, further tighten the top nuts in two passes as listed below. Sequence the tightening in each pass so that the nut on the opposite side, to the extent possible, will be subsequently tightened until all nuts in that pass have been turned. Do not rotate the leveling nut during the top nut tightening.

Anchor-Bolt Size	First Pass	Second Pass	Total Rotation
3"Ø	1/12 Turn	1/12 Turn	1/6 Turn

- Lubricate, place and tighten the jam nuts to snug tight.

Galvanized Steel Notes:

All steel diagonals and struts shall comply with ASTM A53 Grade B, Type E or S; The American Petroleum Institute (API) 5L Grade B; ASTM A500 Grade B; ASTM A500 Grade C; ASTM A1085; API 5L Grade X42; or API 5L Grade X52. These members designated as steel pipe shall have a minimum yield strength of 35 ksi.

All steel chords shall comply with ASTM A500 Grade B, ASTM A500 Grade C, ASTM A1085, API 5L Grade X42 or API 5L Grade X52. These members designated as hollow structural sections (HSS) shall have a minimum yield strength of 42 ksi.

The steel end post shall comply with API 5L Grade X42 or API 5L Grade X52. The post shall have a minimum yield strength of 42 ksi.

All steel shapes, bars and plates shall comply with ASTM A36, ASTM A572 Grade 50, ASTM A709 Grade 36 or ASTM A709 Grade 50.

Steel welding shall be in accordance with the current edition of the AWS Specifications D1.1, Structural Welding Code—Steel.

Ultrasonic testing shall be performed on the post-to-base-plate complete-joint-penetration groove weld.

All steel sections shall be hot-dipped galvanized after fabrication in accordance with ASTM A123. Provide vent holes for galvanizing. Show location and size of vent holes on shop drawings.

Charpy V-notch toughness requirements in accordance with Article 4152.02 of the Standard Specifications shall apply to all steel greater than 1/2 inch in thickness.

Galvanized Steel Fastener Notes:

Galvanized steel fasteners shall be in accordance with Article 2408.03, S and Article 4187.01, C, 2 of the Standard Specifications. Regular nuts and jam nuts shall be ASTM A563 Grade DH heavy hex. Regular nuts may be substituted for jam nuts. Lock washers shall not be substituted for jam nuts. ASTM A449 Type 1 bolts or ASTM F3125 Grade A325-T Type 1 bolts may be substituted for ASTM F3125 Grade A325 Type 1 bolts where necessary to assure proper bolt length and thread length.

Unless otherwise noted on the plans, galvanized steel fasteners shall be tensioned by turn-of-nut method.

U-Bolt Notes:

U-bolts may be made of galvanized steel or stainless steel and shall be in accordance with Article 4187.01, C, 2 of the Standard Specifications. Washers, regular nuts and jam nuts shall use the same alloy properties as those of the U-bolts specified. Regular nuts may be substituted for jam nuts. Lock washers shall not be substituted for jam nuts.

Anchor Bolt Notes:

All anchor bolt materials and galvanizing shall be in accordance with Article 4187.01, C, 3 of the Standard Specifications.

Bending or welding of anchor bolts shall not be allowed.

Anchor bolts shall comply with ASTM F1554 Grade 105.

General Notes:

All steel cantilever truss sign supports are designed for 50 lb/ft² wind pressure on support members and 50 lb/ft² on signs.

Shop drawings shall be submitted by the Contractor in accordance with Article 1105.3 of the Standard Specifications.

Clear distance from face of the concrete to the nearest reinforcing bar shall be 2" unless otherwise shown.

Keyway dimensions shown on the plans are based on nominal dimensions unless stated otherwise. In addition, the bevel used on the keyway shall be limited to a maximum of the 10 degrees from vertical.

Steel cantilever sign trusses shall not be used on bridges without the approval of the Bridges and Structures Bureau.

Structural Alignment/Tolerance Notes:

The precise installation and alignment of all components of the cantilever sign truss and its support shall be considered essential. The Contractor shall submit documentation to the Engineer showing that the various components have been measured and are located within the tolerances listed below.

- The foundation shall be accurately located, with the center of the anchor bolt group not more than 1 inch from the plan location in the direction parallel with the truss and not more than 1 inch from the plan location in the direction perpendicular to the truss.
- Anchor bolts shall be plumb within 1/4 inch per foot from vertical.
- Anchor bolts shall project above top of foundation within 1/4 inch of the plan dimension.
- The truss support post shall be plumb within 1/16 inch per foot of vertical in two perpendicular directions.
- The horizontal lines between chords shall be level within 1/16 inch per foot of horizontal, and the vertical lines between chords shall be plumb within 1/16 inch per foot of vertical.

Specifications:

Design:
AASHTO LRFD Specifications for Structural Supports for Highway Signs, Luminaires and Traffic Signals, Series of 2015 with Interims.

Construction:
Iowa Department of Transportation Standard Specifications for Highway and Bridge Construction, Series 2023, plus applicable General Supplemental Specifications, Developmental Specifications, Supplemental Specifications and Special Provisions shall apply to construction work on this project.

Design Stresses:

Design stresses for materials are in accordance with AASHTO LRFD Specifications for Structural Supports for Highway Signs, Luminaires and Traffic Signals, Series of 2015 with Interims.

Reinforcing steel in accordance with AASHTO LRFD Bridge Design Specifications Series of 2014, Section 5, Grade 60.

Spread footing foundation concrete in accordance with AASHTO LRFD Bridge Design Specifications Series of 2014, Section 5, f'c = 4.0 ksi.

Drilled shaft foundation concrete in accordance with AASHTO LRFD Bridge Design Specifications Series of 2014, Section 5, f'c = 4.0 ksi.

11-2025 Latest Revision Date	 Approved by Bridge Engineer		
		Standard Design <h2 style="margin: 0;">Steel Cantilever Sign Truss</h2> July, 2017	
		Index and Notes	SCST-01-17

Revised 12-2021: Changed designation of encircled Note 2 to encircled Note 3 to permit insertion of new encircled Note 2. Added new encircled Note 2 that allows substitution of HSS 6.625 x 0.562 for HSS 6.625 x 0.500 for truss lengths from 39'-6" to 40'-0".
 Revised 11-2025: This sheet reissued, sheet format update. In Elevation View, changed "Sign Board" to "Main Sign" and added "Auxiliary Sign". In Plan View, changed "Sign Board" to "Sign".
 steelcantileversignstruss.dgn - SCST-02-17 - This sheet issued 07-2017.

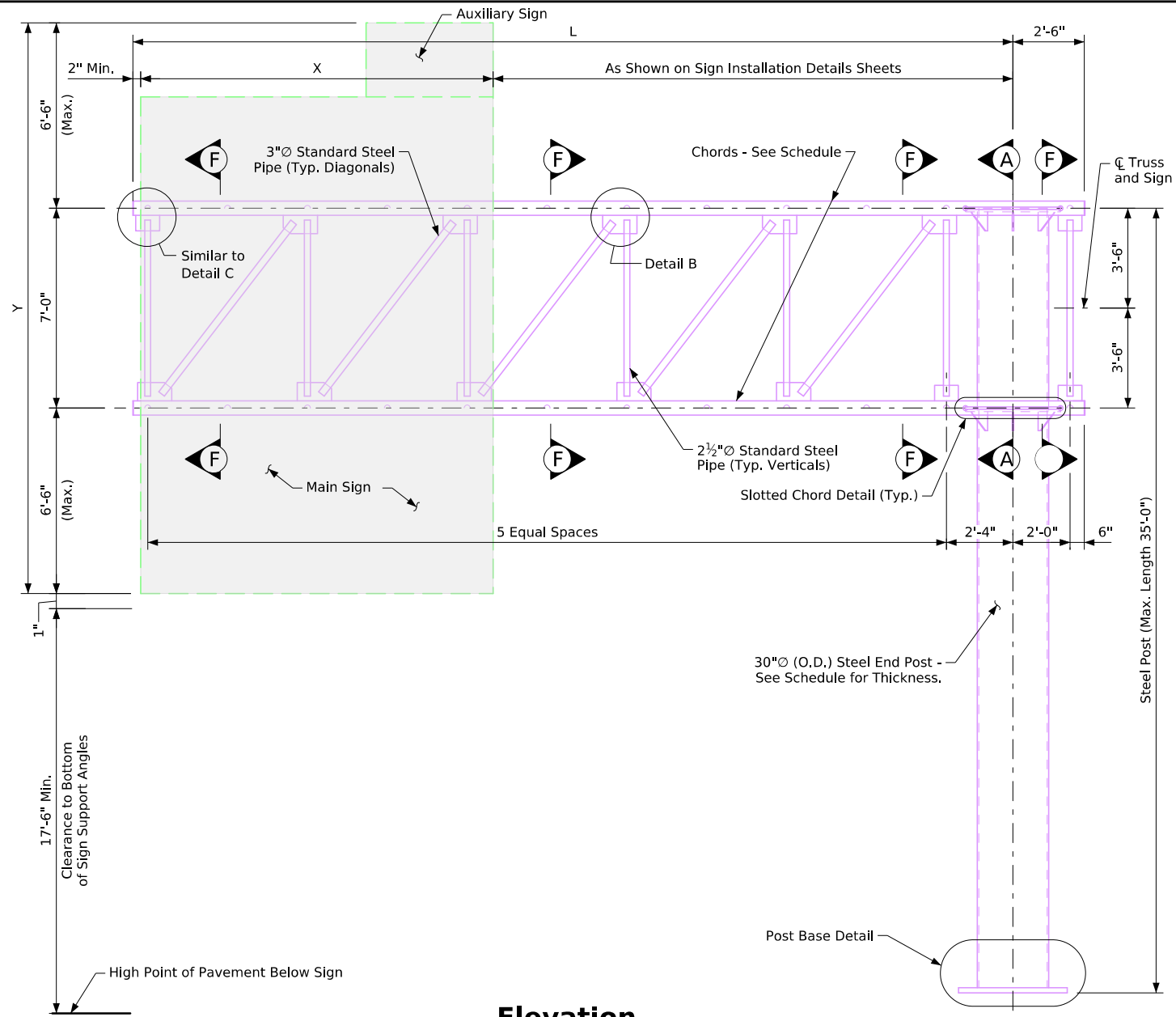

Elevation

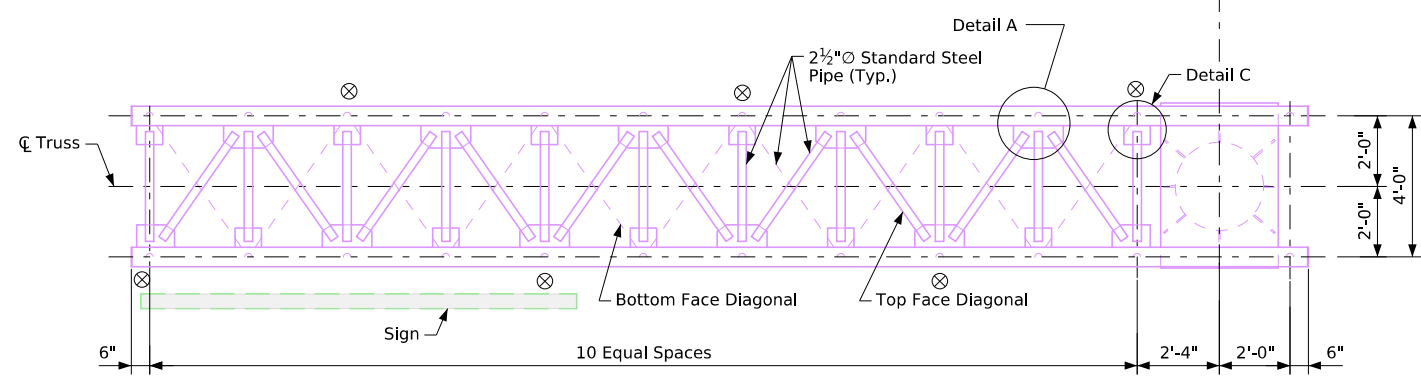

Plan

⊗ Indicates the connection of interior diagonals in vertical plane to the top chord members. See Section F-F.

Max. Truss Length L	Max. Sign Height Y	Max Sign Area X*Y ft ²	Chords	Post Wall Thickness	Camber C
40'-0" ①	20'-0"	400	HSS 6.625 x 0.500 ②	0.625"	4"
38'-0"	20'-0"	400	HSS 6.625 x 0.432	0.625"	3 1/2"
36'-0"	20'-0"	400	HSS 6.625 x 0.432	0.625"	3"
34'-0"	20'-0"	400	HSS 6.625 x 0.375 ③	0.625"	2 1/2"
32'-0"	20'-0"	400	HSS 6.625 x 0.375 ③	0.625"	2 1/2"
30'-0"	20'-0"	400	HSS 6.625 x 0.375 ③	0.625"	2"

- ① Although these standards allow for a truss maximum cantilever length of 40'-0", the Designer should check material availability before selecting a truss length greater than 39'-6". HSS 6.625 chords are typically stocked in 42'-0" lengths. A truss length of 40'-0" requires a total chord length of 42'-6".
- ② HSS 6.625 x 0.562 may be substituted for HSS 6.625 x 0.500 for truss lengths from 39'-6" to 40'-0".
- ③ HSS 6.625 x 0.432 may be substituted for HSS 6.625 x 0.375 for truss lengths from 30'-0" to 36'-0".

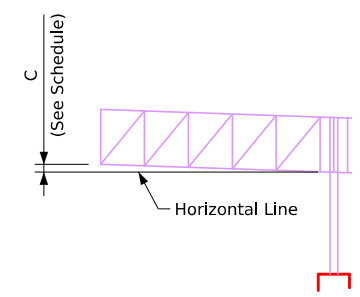

Camber Diagram

See Standard Sheet SCST-04-17 for Section A-A.

See Standard Sheet SCST-05-17 for Details A, B and C; Sections F-F and G-G; and slotted chord detail.

See Standard Sheet SCST-06-17 for post base detail.

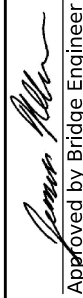
11-2025 Latest Revision Date  Approved by Bridge Engineer	 Standard Design	
	Steel Cantilever Sign Truss July, 2017	
	Sign Support Views	SCST-02-17

• Revised 03-2018: Updated Bridge Engineer signature.
 • Revised 03-2019: Modified note to improve clarity.
 • Revised 11-2025: This sheet reissued, sheet format update.
 • Steelcantilever/signtruss.dgn - SCST-03-17 - This sheet issued 07-2017.

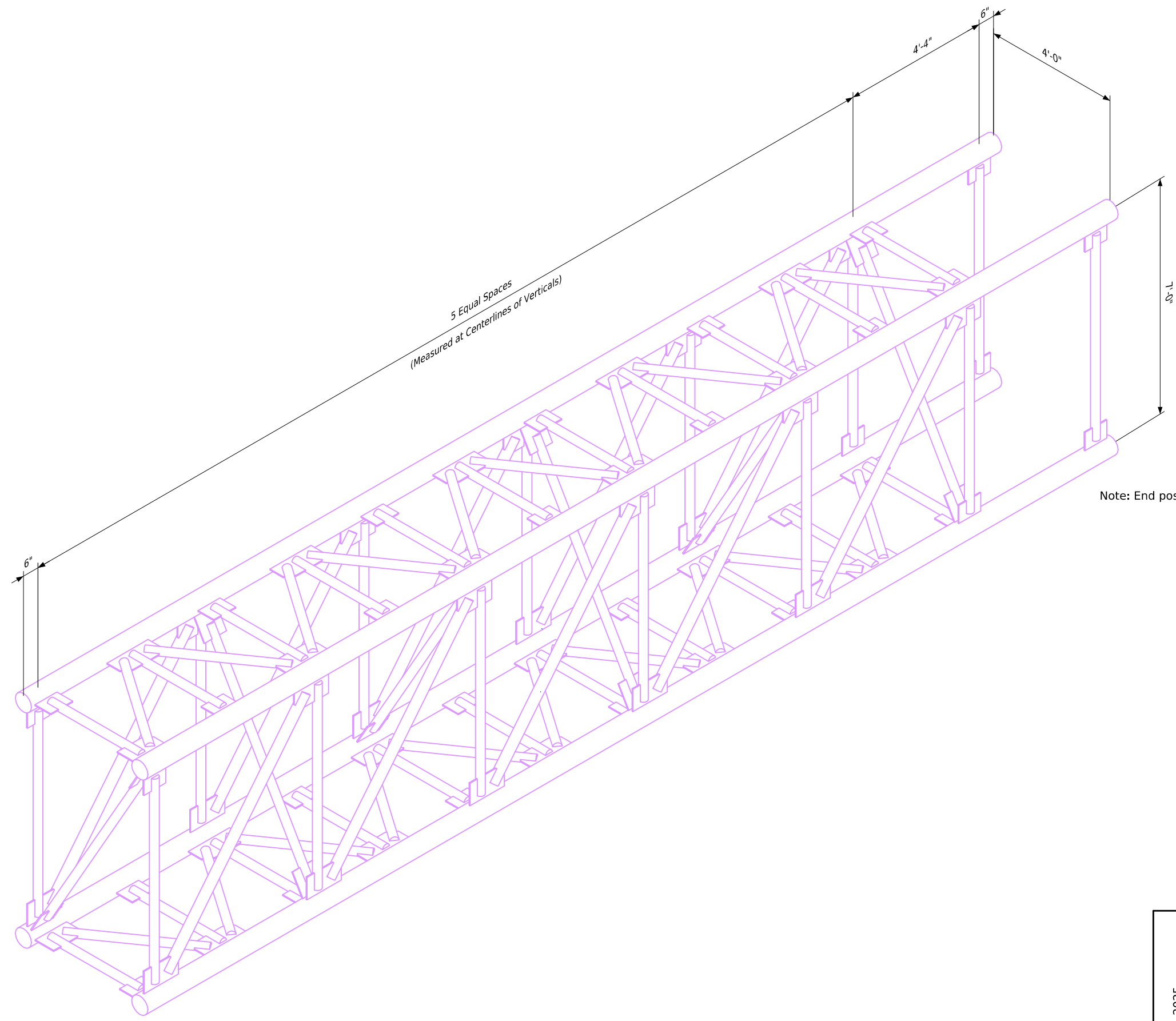

Note: End post not shown for clarity.

11-2025 Latest Revision Date Approved by Bridge Engineer		
	Standard Design Steel Cantilever Sign Truss July, 2017	
	Isometric View of Typical Truss	SCST-03-17

Revised 03-2018: Updated Bridge Engineer signature.
 Revised 03-2019: Added 4" galvanizing holes in plate to improve constructibility. Modified callouts to address change in ASTM Specifications. Added fasteners in Section D-D and Section E-E to improve clarity.
 Revised 11-2025: This sheet reissued, sheet format update.
 Steelcantilever/signtruss.dgn - SCST-04-17 - This sheet issued 07-2017.

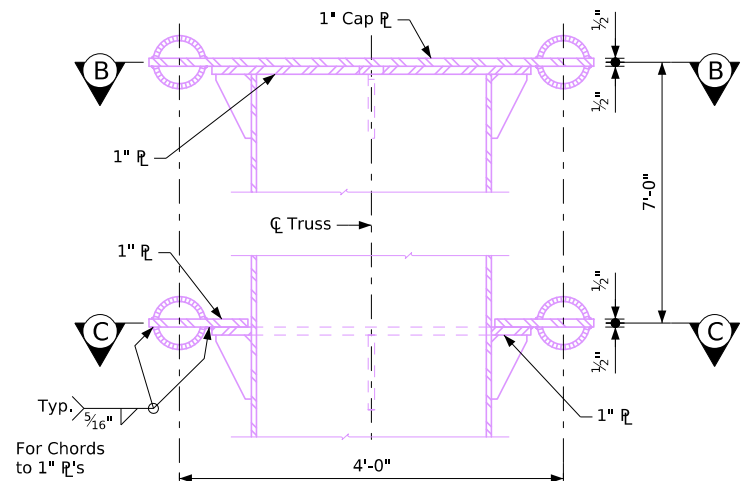

Section A-A

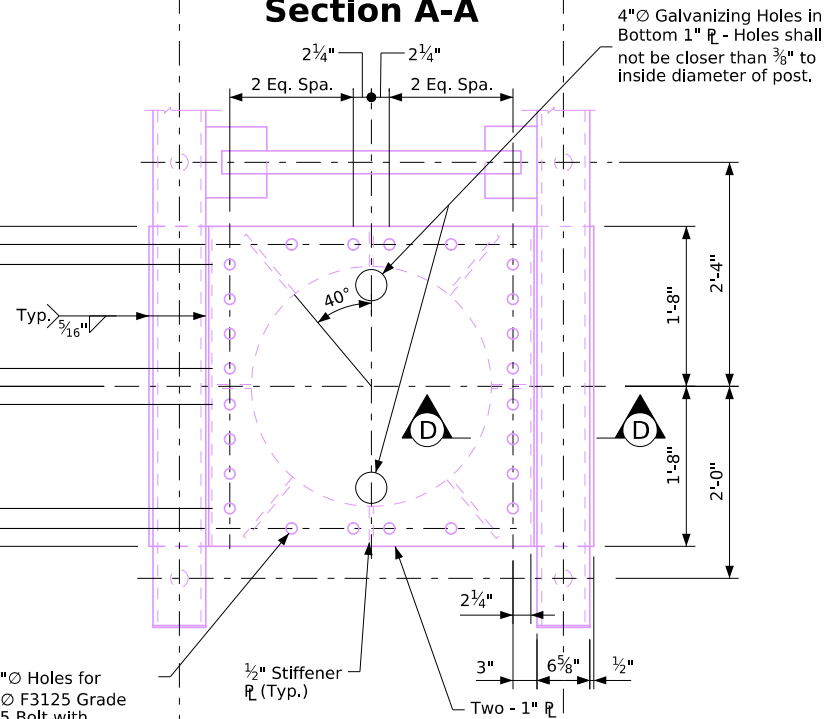

Section B-B

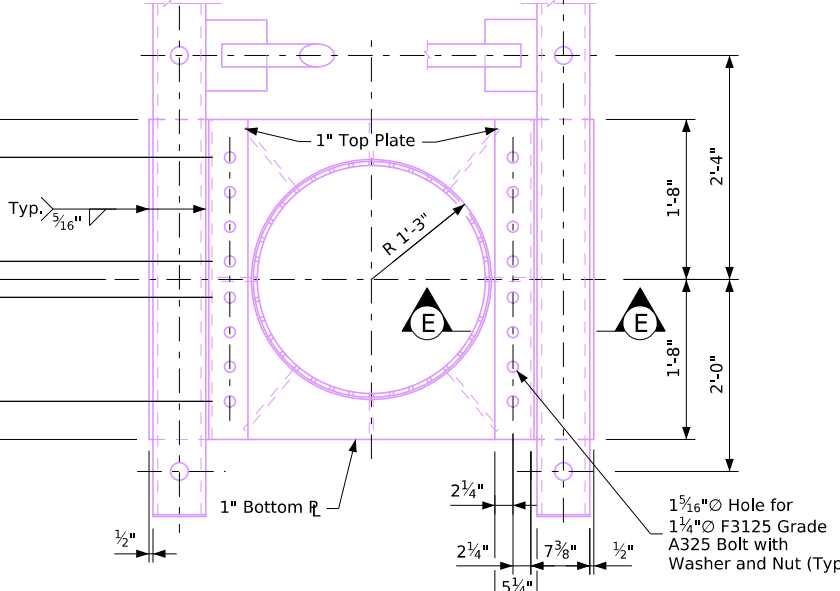

Section C-C

4" Galvanizing Holes in Bottom 1" R - Holes shall not be closer than 3/8" to inside diameter of post.

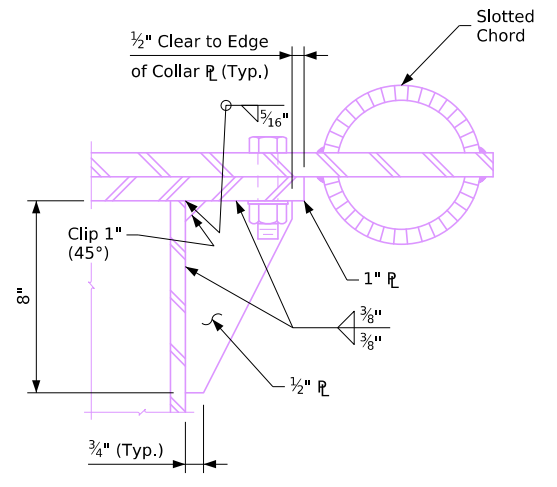

Section D-D

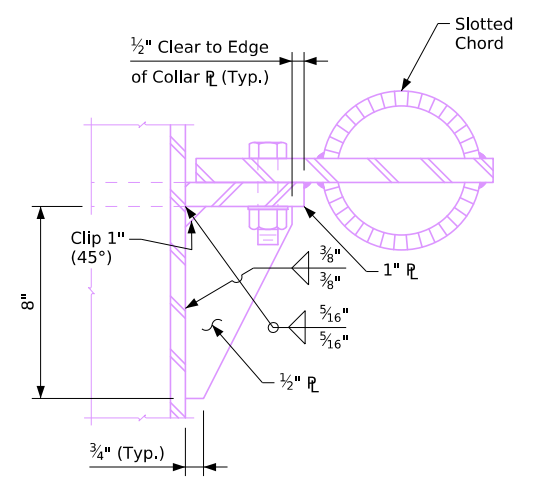

Section E-E

See Standard Sheet SCST-02-17 for location of Section A-A.

11-2025 Latest Revision Date Approved by Bridge Engineer 		
	Standard Design Steel Cantilever Sign Truss July, 2017	
	Truss-to-Post Connection Details	SCST-04-17

Revised 03-2018: Updated bridge Engineer signature.
 Revised 03-2019: Modified formatting of callouts to improve clarity.
 Revised 04-2020: Lengthened dimensional extension line in Details A and B to clarify 2" distance between end of web members and chords. Added 3/4" dimension to clarify location of set screws in end cap detail. Lengthened dimensional extension line in slotted-pipe-ends detail to clarify that dimensional extension line is tangent to circular hole.
 Revised 11-2025: This sheet reissued, sheet format update.
 Steelcantileverstruss.dgn - SCST-05-17 - This sheet issued 07-2017.

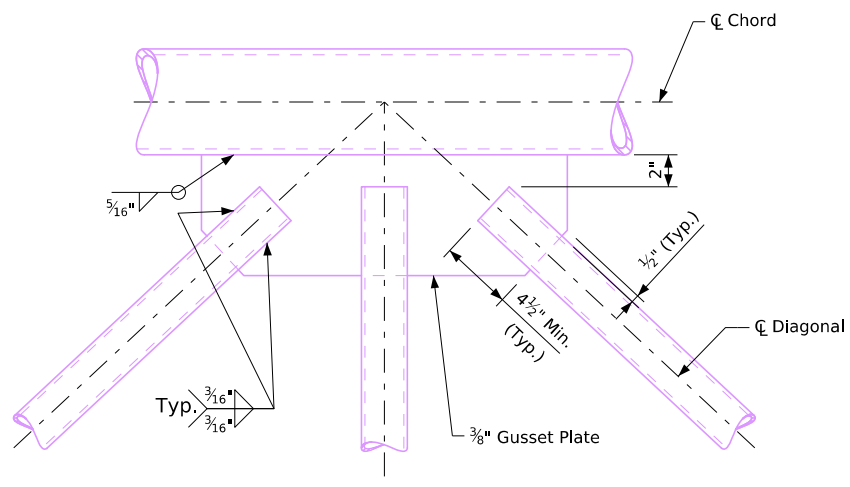

Detail A

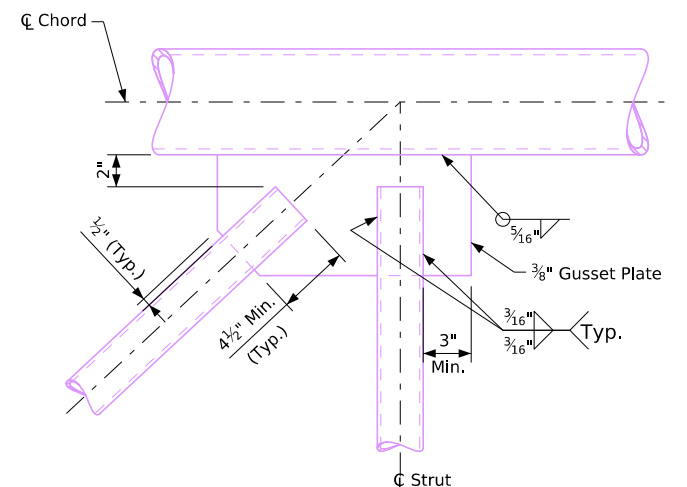

Detail B

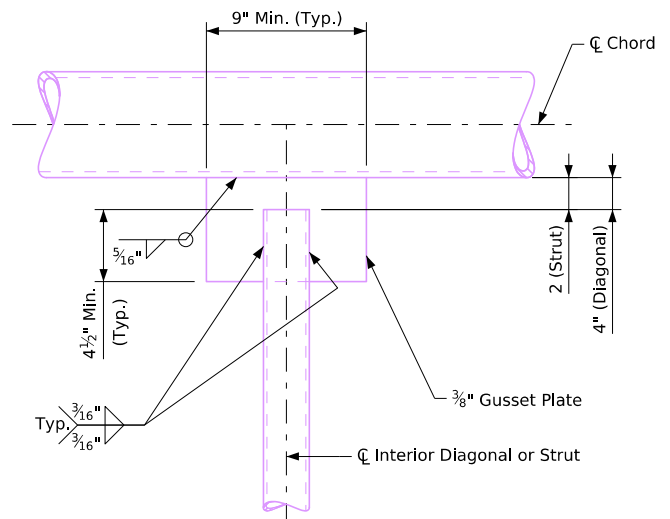

Detail C

Detail A, Detail B, and Detail C show connections at top chords. Connections at bottom chords are similar.

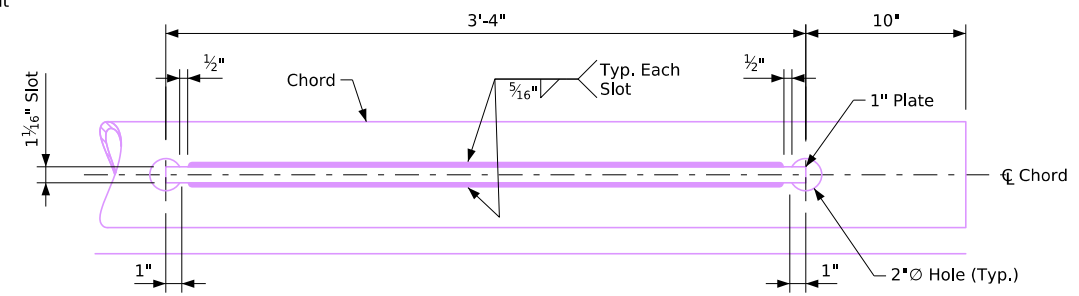

Slotted Chord Detail
Typical at Chord-to-1" Plate Connections

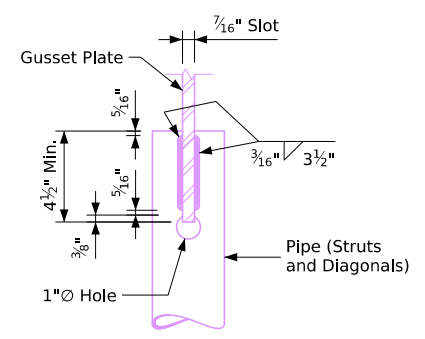

Slotted Pipe Ends
Typical for Struts and Diagonals

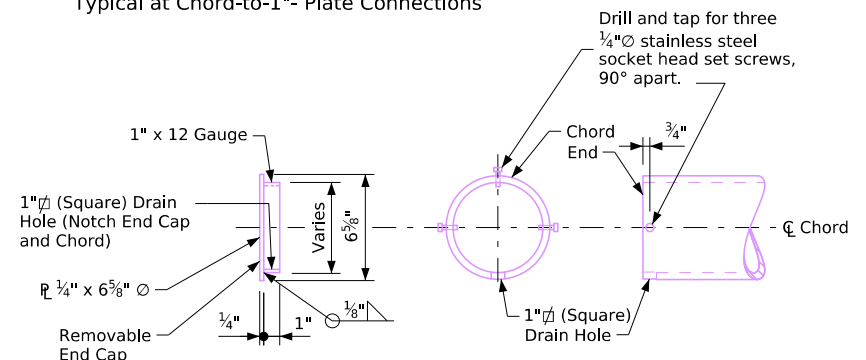

End Cap Detail
Typical for Ends of Chords

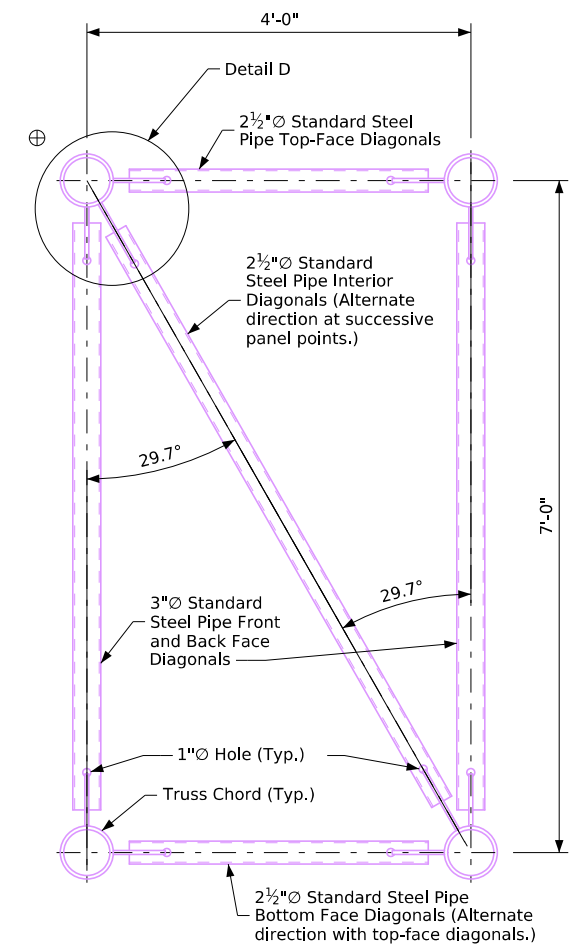

Section F-F

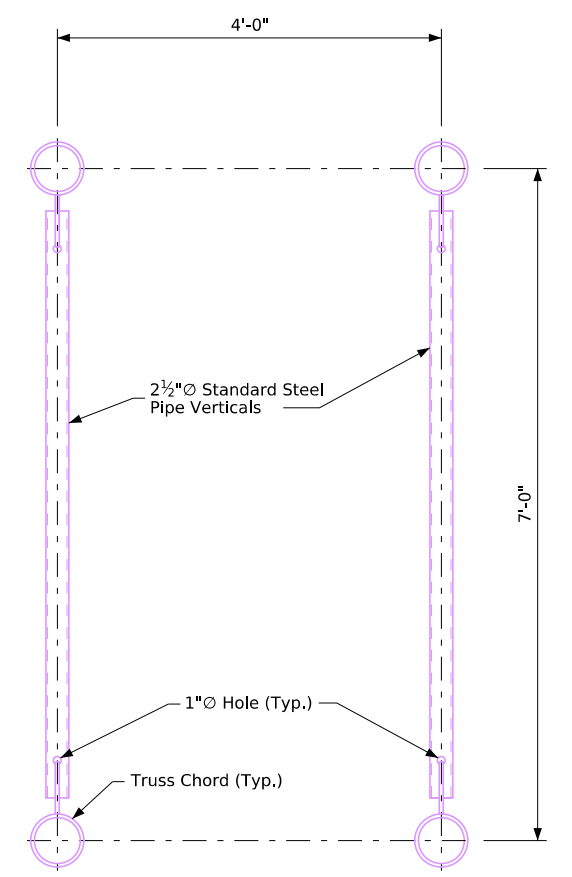

Section G-G

⊕ Indicates the connection of interior diagonals in vertical plane to the top chord members. See Section F-F.

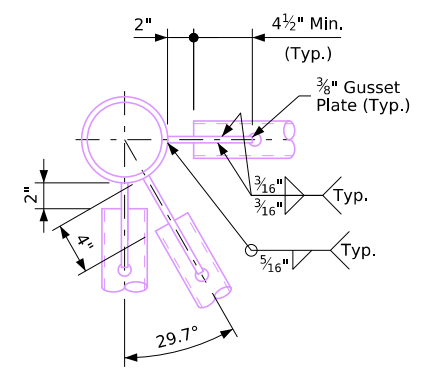

Detail D

See Standard Sheet SCST-02-17 for Locations of Details A, B and C and Sections F-F and G-G.

11-2025 Latest Revision Date	Approved by Bridge Engineer <i>[Signature]</i>	IOWA IDOT	
		Standard Design	
		Steel Cantilever Sign Truss	
		July, 2017	
		Gusset Plate Connection Details	SCST-05-17

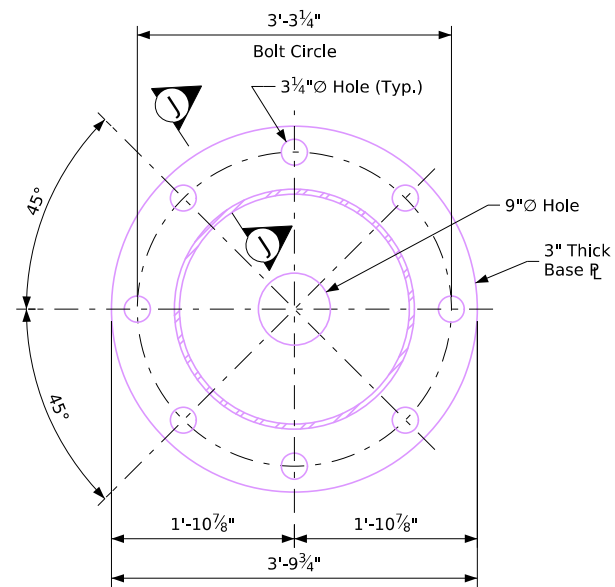

Section H-H

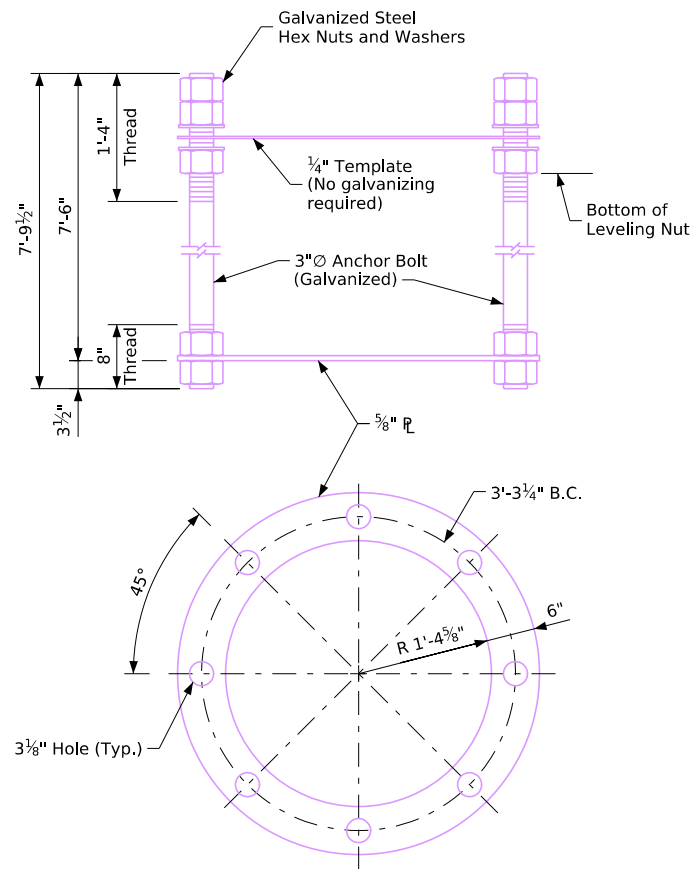

Anchor Bolt Assembly

All anchor bolt materials and galvanizing shall be in accordance with Article 4187.01,C,3 of the Standard Specifications.

Weight of the anchor bolt assembly: 2063 lbs. (includes template, excludes galvanizing weight)

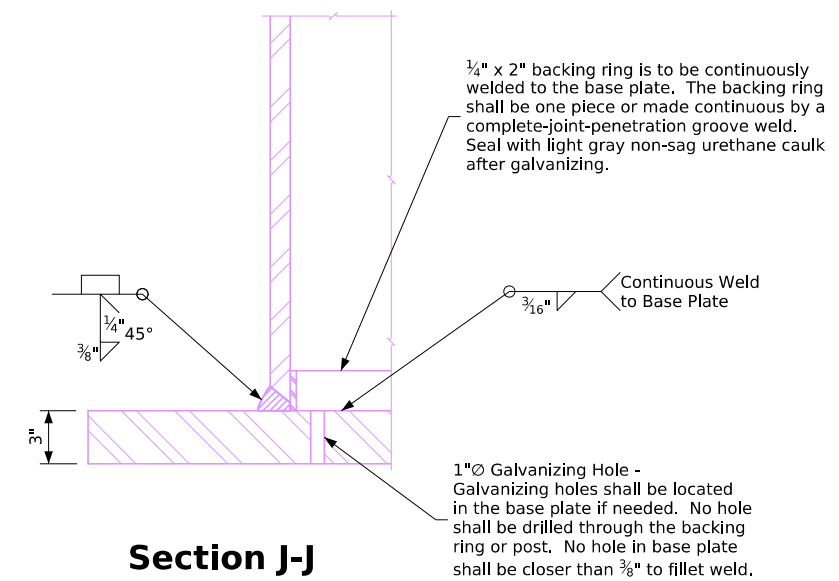

Section J-J

1/4" x 2" backing ring is to be continuously welded to the base plate. The backing ring shall be one piece or made continuous by a complete-joint-penetration groove weld. Seal with light gray non-sag urethane caulk after galvanizing.

1" Galvanizing Hole - Galvanizing holes shall be located in the base plate if needed. No hole shall be drilled through the backing ring or post. No hole in base plate shall be closer than 3/8" to fillet weld.

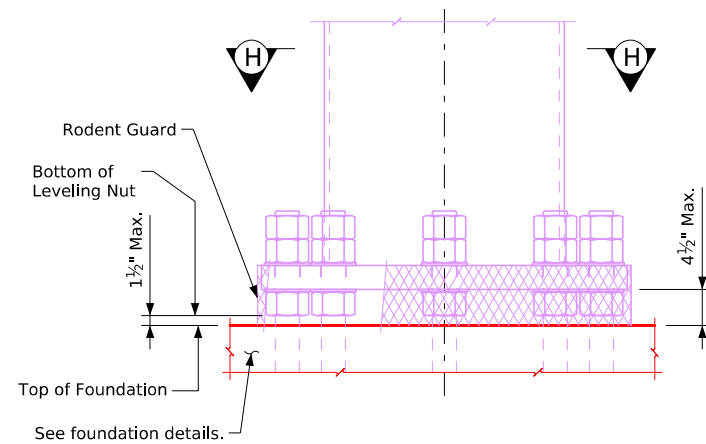

Post Base Detail

Showing the Rodent Guard

The rodent guard shall be placed around the base plate.

The rodent guard is stainless steel standard grade wire cloth, 1/4" maximum opening with a minimum wire diameter of AWG No. 16 with a minimum 2" lap.

Secure wire cloth to base plate after erection with 3/4" stainless steel banding. The rodent guard shall not extend above the top of the base plate.

11-2025 Latest Revision Date Approved by Bridge Engineer 		
	Standard Design Steel Cantilever Sign Truss July, 2017	
	Post Base Support Details	SCST-06-17

Revised 04-2020: Changed "Galvanizing vent Hole" to "Galvanizing hole" in section J-J to reflect hole use as a galvanizing vent hole and/or a galvanizing drain hole. Revised Section J-J post-to-base-plate weld symbol to show a standard-sized backing element. Change "Full-Penetration Groove Weld" to "Complete-Joint-Penetration Groove Weld" to conform to AWS nomenclature. Added callout in anchor bolt assembly detail to clarify that anchor bolt holes in annular plates have a 3/8" diameter. Changed "3/4" Hole (Typ.)" to "3/4" Hole (Typ.)" in Section H-H for uniformity.
 Revised 11-2025: This sheet reissued, sheet format update.
 Steelcantilever/signtruss.dgn - SCST-06-17 - This sheet issued 07-2017.

Revised 04-2020: Changed "Office of Bridges and Structures" to "Bridges and Structures Bureau". Designated L 3 x 3 x 3/8 x 1'-6" as a mating angle for clarity in Part Sign Truss Plan, Section K-K, and Section L-L. Added additional detail to Section L-L and modified callouts to clarify that direction of angle leg is to alternate at successive supports for both sign support angles and mating angles. Moved Section K-K cut line in Part Sign Truss Plan to accurately reflect location of orientation of top-chord-to-mating-angle U-bolt connection for uniformity with detail on SOST-11 Standards.
 Revised 11-2025: This sheet reissued, sheet format update. At various locations, changed "Sign Panel" to "Sign", changed "Main Sign Panel" to "Main Sign" and changed "Supplementary Sign Panel" to "Auxiliary Sign".
 Steelcantilever/signtruss.dgn - SCST-07-17 - This sheet issued 07-2017.

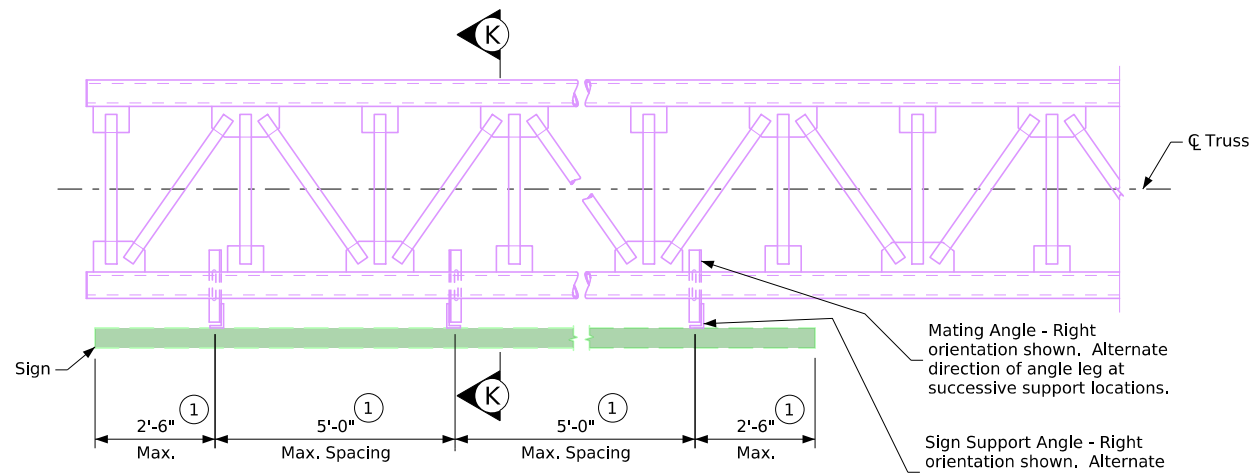

Part Sign Truss Plan

Mating Angle - Right orientation shown. Alternate direction of angle leg at successive support locations.
 Sign Support Angle - Right orientation shown. Alternate direction of angle leg at successive support locations.

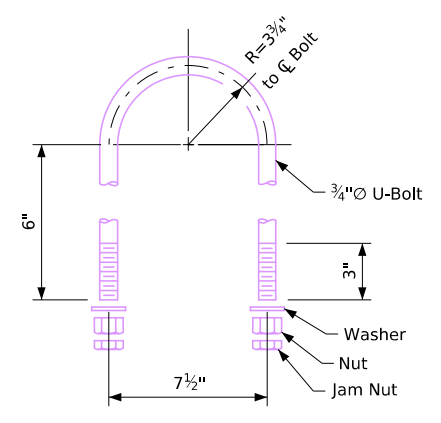

U-Bolt Detail

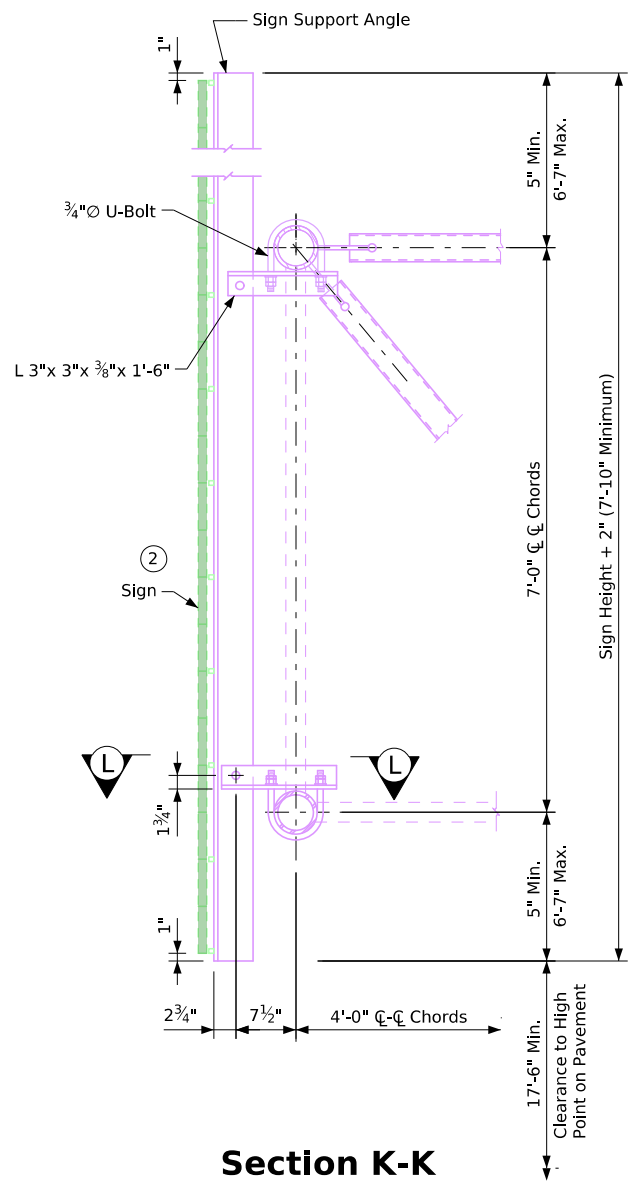

Section K-K

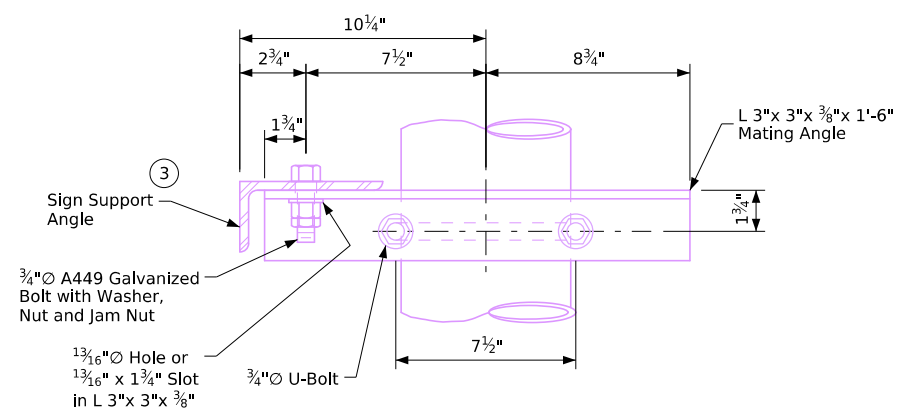

(Left Orientation)

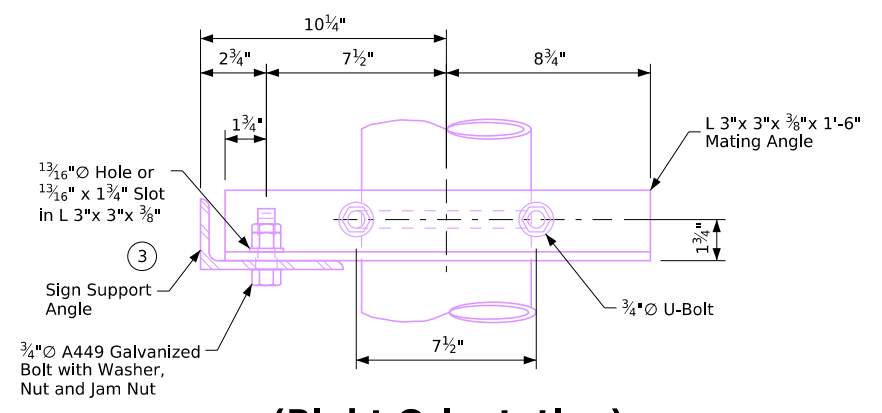

(Right Orientation)

Section L-L

Alternate direction of sign support angle leg and mating angle leg at successive supports as shown in Part Sign Truss Plan.

- ① Dimension restrictions apply to main sign and any auxiliary signs that may be present.
- ② Center the main sign vertically on the truss if the auxiliary sign length is less than half the length of the main sign, otherwise center the combined height of the main sign and auxiliary sign vertically on the truss.
- ③ Use L 6"x 3 1/2"x 1/2" for sign height over 10'-0" to 20'-0" and L 5"x 3"x 3/8" for sign height of 10'-0" or less. A total sign height greater than 20'-0", sign vertical cantilever length greater than 6'-7", and/or sign support angle horizontal spacing greater than 5'-0" requires approval by the Bridges and Structures Bureau.

11-2025 Latest Revision Date	Approved by Bridge Engineer <i>Jenna Miller</i>	IOWA IDOT	
		Standard Design	
		Steel Cantilever Sign Truss	
		July, 2017	
		Sign Attachment Details	SCST-07-17

Revised 03-2018: Updated Bridge Engineer signature.
 Revised 03-2019: Added two special bid items ("Anchor Bolt Assembly--Furnish" and "Anchor Bolt Assembly--Install and Survey") to clarify Contractor responsibility to accurately install anchor bolt assembly.
 Reordered notes to improve readability.
 Revised 11-2025: This sheet reissued, sheet format update.
 Steelcantileversigntruss.dgn - SCST-08-17 - This sheet issued 07-2017.

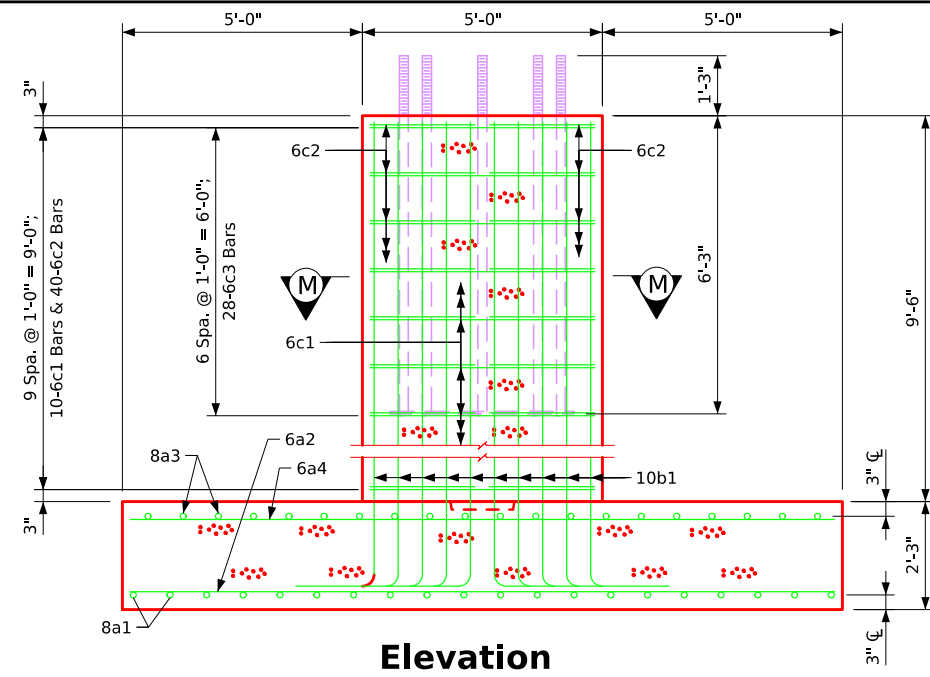

Elevation

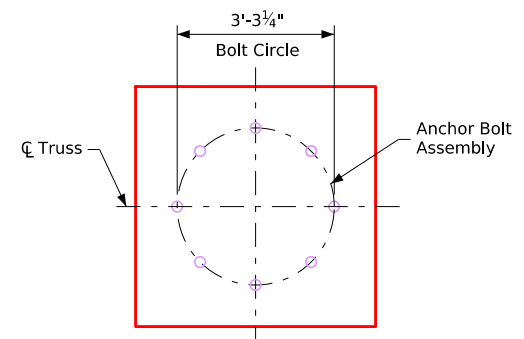

Top View

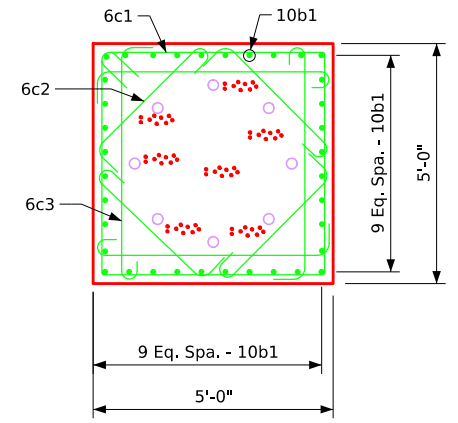

Section M-M

4-6c3 bars are to be placed with every layer of 6c1 bars in the top 6'-3" of the pedestal.

Concrete Placement Quantities

Pedestal	8.8
Footing	25.0
Total - C.Y.	33.8

Reinforcing Bar List - Epoxy Coated

Bar	Location	Shape	No.	Length	Weight
8a1	Footing Bott., Longit.		20	19'-8"	1050
6a2	Footing Bott., Transv.		31	14'-8"	683
8a3	Footing Top, Longit.		20	19'-8"	1050
6a4	Footing Top, Transv.		31	14'-8"	683
10b1	Footing to Pedestal Dowel		36	13'-3"	2053
6c1	Pedestal Ties		10	19'-8"	295
6c2	Pedestal Ties		40	4'-4"	260
6c3	Pedestal Ties		28	6'-7"	277
Epoxy Coated Reinforcing Steel - Total (lbs.)					6351

Bent Bar Details

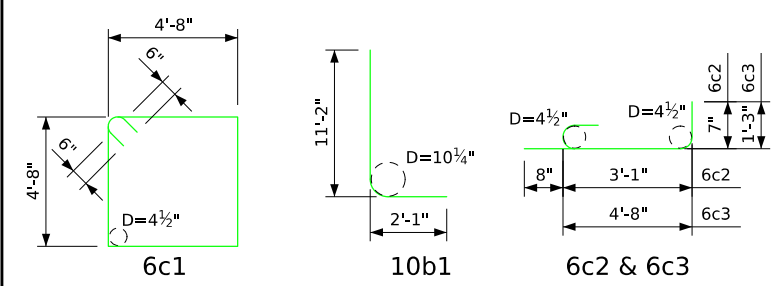

Note: All dimensions are out to out. D = Pin Diameter.

General Notes:

Structural concrete, Class C, shall be used for the foundation.

All exposed corners 90° or sharper shall be filleted with a 3/4" dressed and beveled strip.

Excavation for the foundation shall be to neat lines and concrete shall be placed against the undisturbed material. All excavation for the foundation shall be disposed in the area adjacent to the foundation and shaped to normal ground contour, unless otherwise directed by the Engineer.

One anchor bolt assembly including anchor plate, template, nuts (5 per bolt) and washers (2 per bolt) are required per foundation.

All anchor bolt materials and galvanizing shall be in accordance with the requirements of Article 4187.01, C, 3 of the Standard Specifications.

The foundation details shown are based on a net allowable soil bearing pressure (for settlement) of 1.0 ton/ft².

Price bid for contract items shall include all labor and materials necessary to construct cantilever sign truss foundation as detailed hereon. The cost of furnishing and installing rodent guard shall be included in the price bid for "Structural Concrete (Miscellaneous)" and no separate payment will be made. The cost of furnishing anchor bolt assembly shall be included in the price bid for "Anchor Bolt Assembly--Furnish". (Note that this is a special bid item.) The cost of accurately installing and surveying anchor bolt assembly shall be included in the price bid for "Anchor Bolt Assembly--Install and Survey". (Note that this is a special bid item.) See structural alignment/tolerance notes on Standard Sheet SCST-01-17 for anchor bolt assembly alignment documentation requirements. Contract items for cantilever sign truss foundation construction are:
 Reinforcing Steel, Epoxy Coated - pounds
 Structural Concrete (Miscellaneous) - cubic yards
 Excavation - cubic yards of class specified
 Anchor Bolt Assembly--Furnish (special bid item) - pounds
 Anchor Bolt Assembly--Install and Survey (special bid item) - each

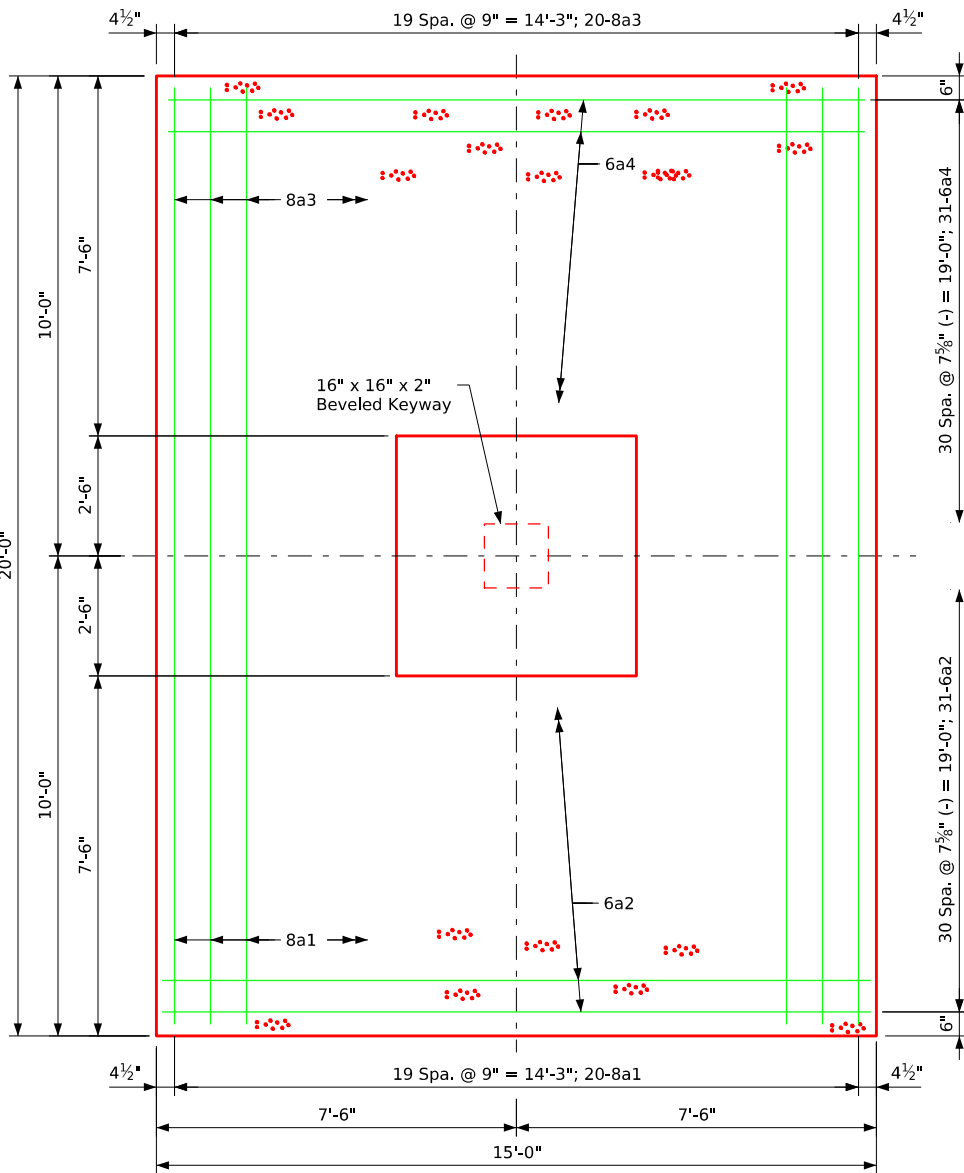

Footing Plan

Top Reinf. Steel

Bottom Reinf. Steel

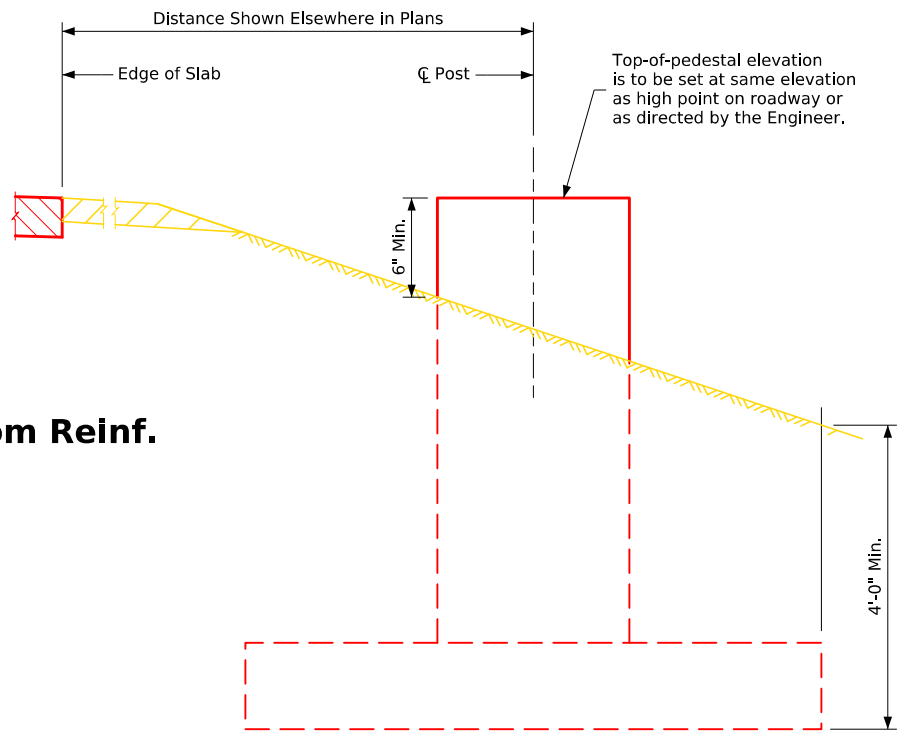

Elevation - Top of Pedestal and Backfill

11-2025 Latest Revision Date Approved by Bridge Engineer	 Standard Design
	Steel Cantilever Sign Truss July, 2017
	Foundation Details - Spread Footing SCST-08-17

Revised 03-2018; Updated Bridge Engineer signature.
 Revised 03-2019; Added notes including bid item note to improve clarity. New bid item list includes two special bid items ("Anchor Bolt Assembly--Furnish" and "Anchor Bolt Assembly--Install and Survey") to clarify Contractor responsibility to accurately install anchor bolt assembly. Reordered notes to improve readability. Modified alternate 6c1 shaft circular ties to include 135° hooks.
 Revised 11-2025; This sheet reissued, sheet format update. Changed concrete drilled shaft diameter from 30 in. to 60 in. in Contract Item list to match dimension shown in Section N-N. Modified soil condition note to clarify that a soil confirmation boring is required prior to contract letting.
 Steelcantilever.truss.dgn - SCST-09-17 - this sheet issued 07-2017.

Drilled Shaft Quantities			
Truss Length	Shaft Length "L"	Epoxy Coated Rebar	Structural Concrete
30 ft.	24 ft.	4531 lbs.	17.45 C.Y.
32 ft.	25 ft.	4701 lbs.	18.18 C.Y.
34 ft.	27 ft.	5041 lbs.	19.63 C.Y.
36 ft.	29 ft.	5381 lbs.	21.09 C.Y.
38 ft.	31 ft.	5721 lbs.	22.54 C.Y.
40 ft.	33 ft.	6061 lbs.	24.00 C.Y.

Reinforcing Bar List - Epoxy Coated								
Bar	Location	Shape	Tabulated Value For L = 24'-0"			Each Additional 1'-0" of L		
			No.	Length	Weight	No.	Length	Weight
10b1	Shaft Vertical		32	23'-3"	3201	32	1'-0"	138
6c1	Shaft Circular Ties (Alternate)		32	18'-1"	0	1.33	18'-1"	0
6c2	Shaft Ties		72	4'-10"	522	0	4'-10"	0
#6	Shaft Spiral		1	487'-11"	733	1	19'-2"	29
	Spiral Spacer L 1"x 1"x 1/8"		4	23'-3"	75	4	1'-0"	3
					total 4531 lbs.	total 170 lbs.		

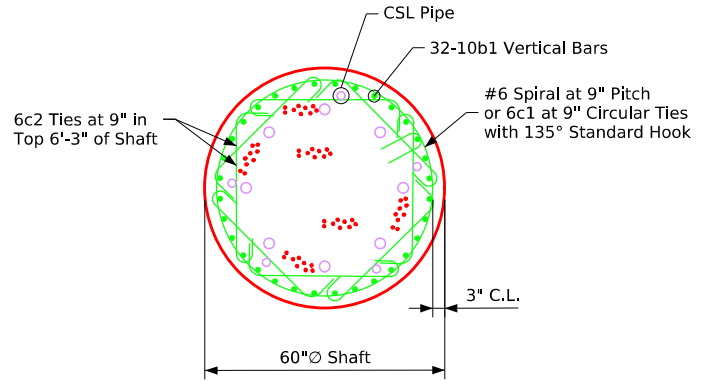
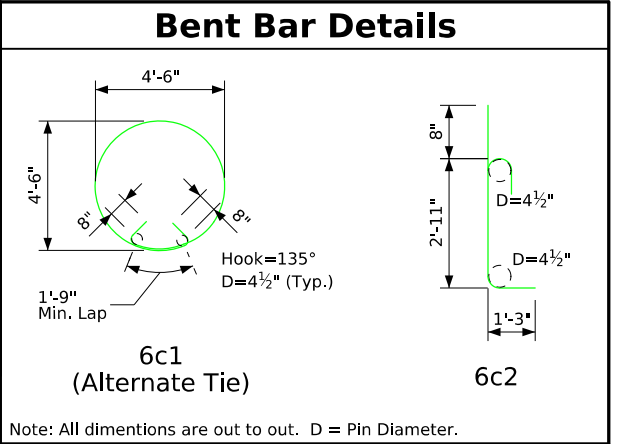

Section N-N
 8 - 6c2 ties are to be placed with every layer of #6 spiral/6c1 circular ties in the top 6'-3" of the shaft.

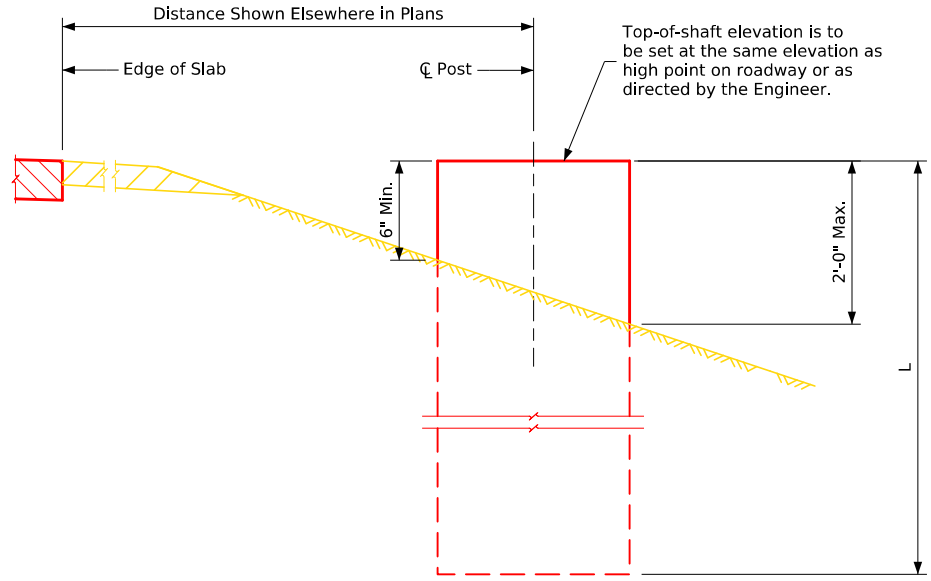
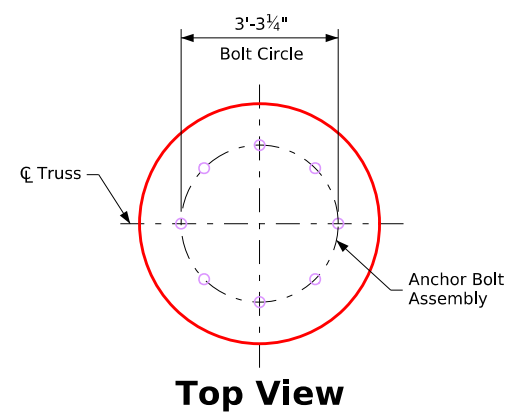

Elevation - Top of Shaft and Backfill

General Notes (Continued):

Drilled shaft shall have crosshole sonic logging (CSL) pipes as shown. CSL pipes shall be placed in a pattern so that each pipe is spaced the maximum distance possible from adjacent pipes.

A normal surface finish followed by a concrete sealer application is required on concrete surfaces above the lowest elevation 6" below finished ground line.

Price bid for contract items shall include all labor and materials necessary to construct cantilever sign truss foundation as detailed hereon. The cost of furnishing and installing rodent guard shall be included in the price bid for "Structural Concrete (Miscellaneous)" and no separate payment will be made. The cost of furnishing anchor bolt assembly shall be included in the price bid for "Anchor Bolt Assembly--Furnish". (Note that this is a special bid item.) The cost of accurately installing and surveying anchor bolt assembly shall be included in the price bid for "Anchor Bolt Assembly--Install and Survey". (Note that this is a special bid item.) See structural alignment/ tolerance notes on Standard Sheet SCST-01-17 for anchor bolt assembly alignment documentation requirements. Contract items for cantilever sign truss foundation construction are:

- Reinforcing Steel, Epoxy Coated - pounds
- Reinforcing Steel - pounds
- Structural Concrete (Miscellaneous) - cubic yards
- Concrete Drilled Shaft, 60 in. diameter - linear feet
- Class 20 Excavation - cubic yards
- Anchor Bolt Assembly--Furnish (special bid item) - pounds
- Anchor Bolt Assembly--Install and Survey (special bid item) - each

General Notes:

Structural Concrete, Class C, shall be used for the drilled shaft.

All exposed corners 90° or sharper shall be filleted with a 3/4" dressed and beveled strip.

Spiral reinforcing is to be No. 6 bar with a 4'-6" outside diameter and 9" pitch with 4 equally spaced L 1"x 1"x 1/8" spacers punched to hold spirals. Spirals are to have 1 1/2 extra turns at top and bottom of shaft.

The spiral reinforcing may be spliced by lapping 3'-1". The length of the spiral shown does not include the lapped length of the splices. The cost of the laps at splices is to be included in the price bid for other reinforcement.

Circular ties may be substituted for the spiral reinforcement. Payment will be based on the weight of spiral reinforcement. No adjustments in reinforcing steel pay weight will be allowed. See bent bar details for alternate tie configuration.

All reinforcing is to be securely wired in place before concrete is poured.

One anchor bolt assembly including anchor plate, template, nuts (5 per bolt) and washers (2 per bolt) are required per foundation.

All anchor bolt materials and galvanizing shall be in accordance with the requirements of Article 4187.01, C, 3 of the Standard Specifications.

The foundation details shown are based on common cohesive soil conditions (silty or sandy clay) with an average unconfined compressive strength (q_u) of at least 1.25 ton/ft². These properties must be confirmed by soil investigations at the site prior to project letting. When other conditions are indicated, the boring data will be included in the plans and the foundation embedment will be the result of site specific designs.

If the soil conditions encountered are different than those required in these General Notes, the Contractor shall notify the Engineer to determine if the foundation embedment needs to be modified. If the embedment is revised by more than 12" by the Contractor, "As-built" plans shall be prepared and submitted to the Iowa DOT for future reference.

Design embedment lengths listed in the shaft embedment table are based on a soil undrained cohesion of 0.625 ton/ft², a soil effective unit weight of 57.6 lb/ft³, and a soil strain factor (E50) of 0.007.

Excavations shall be dewatered before concrete placement at no additional cost to the State.

Concrete shall be placed monolithically without construction joints.

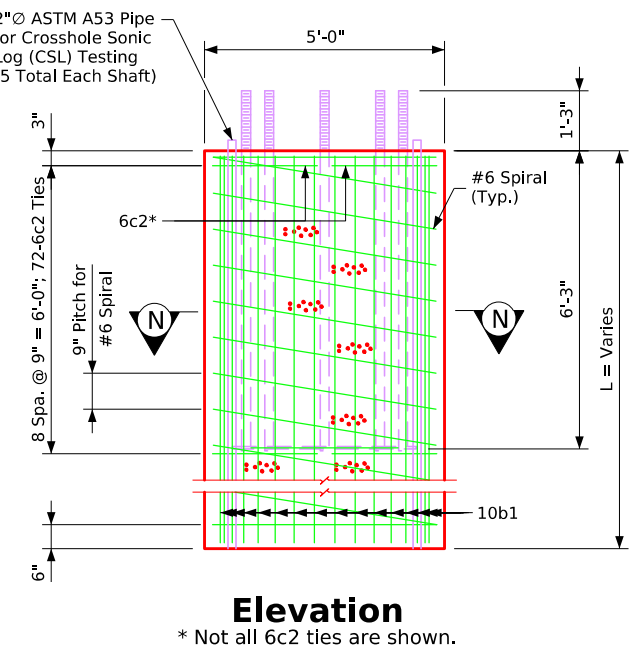

11-2025 Latest Revision Date		IOWA DOT	
		Standard Design	
		Steel Cantilever Sign Truss	
		July, 2017	
		Foundation Details - Drilled Shaft	SCST-09-17